



## Battery Range Summary



EnerSys' new DataSafe® XE range of front terminal batteries has been specifically developed to meet the challenging demands of the modern UPS market sector. UPS batteries that historically focused on a 15 minute rate discharge have become increasingly ineffective in fulfilling the growing need for sub five minute autonomies. Furthermore, the pressure to lower energy costs by minimising air conditioning in equipment rooms results in a trend towards higher operating temperatures.

To meet these requirements, EnerSys has optimised its world-renowned, advanced Thin Plate Pure Lead (TPPL) technology to deliver five monoblocs with outstanding features and benefits. Unlike typical VRLA AGM technology UPS batteries, DataSafe front terminal 12XE1010F-FR, 12XE1110F-FR and 12XE1150F-FR and top terminal 12XE760-FR and 12XE1040-FR monoblocs provide the perfect solution to the ever-evolving requirements of today's datacentre world.

### Features & Benefits

- 763, 1010, 1040, 1109 & 1150 Watts per cell sizes
- Specifically designed for 30 seconds to 5 minutes high-rate discharge applications
- Pure lead technology for longer life at elevated temperatures
- 12+ year design life at 20°C
- Up to 24 month shelf life for maximum flexibility in project deployment
- Outstanding power density in industry-standard footprints
- Fast recharge times to support multiple AC outages
- Low energy consumption compared to traditional VRLA AGM batteries
- Front termination design for ease of installation and maintenance
- Top terminal design for upgrades to existing applications

Visit us at [www.enersys.com](http://www.enersys.com)

**EnerSys**

Power/Full Solutions

RESERVE  
POWER

## Construction

- High performance TPPL grids for optimised corrosion resistance at high operating temperatures
- Active material specifically engineered for maximum performance at sub 5 minute discharge rates
- Enhanced internal connections designed for high rate UPS loads
- Superior quality microporous glass mat separator with high absorption and stability
- Containers and lids in UL94 V-0 rated flame retardant ABS material, highly resistant to shock and vibration
- High grade dilute sulphuric acid electrolyte absorbed into separator material
- High integrity leak resistant dual-seal terminal design
- Self-regulating pressure relief valves prevent ingress of atmospheric oxygen

- Flame arrestors built into each bloc for increased operational safety
- Robust handles for ease of handling

## Installation & Operation

- Monoblocs are designed for installation in cabinets or on stands, close to the point of use. A separate battery room is not necessary
- It is recommended that DataSafe® XE blocs are installed on their base
- Recommended float charge voltage: 2.27Vpc at 25°C (2.29Vpc at 20°C)
- Low maintenance: no water addition required
- Wide operating temperature range: -40°C to +50°C
- Front terminal connection torque: 9Nm - 80lbf in;  
Top terminal connection torque: 6.8Nm - 60lbf in
- Up to 24 month shelf life

## Standards

- Designed to be compliant with the requirements of international standard IEC 60896-21/22
- Classified as "Very Long Life" (>12 years) according to the 2015 Eurobat guide
- UL recognised component
- Classified as non-spillable and approved as non-hazardous cargo for ground, sea and air transportation in accordance with the requirements of IMDG (International Maritime code for Dangerous Goods) and ICAO (International Civil Aviation Organisation)
- The management systems governing the manufacture of DataSafe XE products are ISO 9001:2008, ISO 14001:2004 and OHSAS 18001:2007 certified\*

\*OHSAS 18001:2007 certification not applicable to 12XE760-FR

## General Specifications

Battery Type	Nominal Voltage (V)	Watts/Cell (Wpc)		Nominal Capacity (Ah)		Nominal Dimensions (mm)			Typical Weight (kg)	Short Circuit Current (A) <sup>(1)</sup>	Internal Resistance (mΩ) <sup>(1)</sup>	Terminals
		5min/1.67Vpc /25°C	15min/1.67Vpc /25°C	C <sub>100</sub> /1.80Vpc /20°C	C <sub>100</sub> /1.75Vpc /25°C	Length	Width	Overall Height				
12XE760-FR	12	763	390	92	93	330	173	222	35.1	3100	4.00	M6 female
12XE1040-FR	12	1040	560	124	129	338	173	273	44.0	4150	3.30	M6 female
12XE1010F-FR	12	1010	566	155	158	561	125	283	48.7	3498	3.56	M6 male
12XE1110F-FR	12	1109	649	165	167	561	125	283	51.7	3916	3.20	M6 male
12XE1150F-FR	12	1150	706	180	181	561	125	316	58.6	4081	3.07	M6 male

Note:  
<sup>(1)</sup> Figures obtained via IEC method.

## Outline Drawings

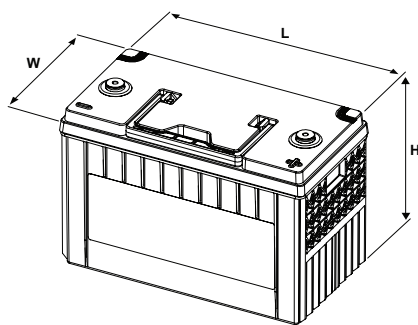

12XE760-FR

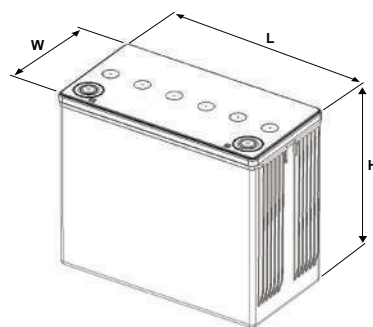

12XE1040-FR

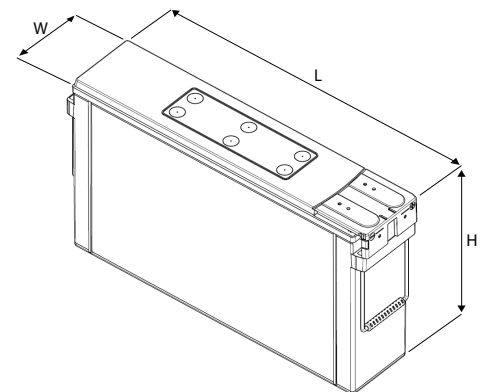

12XE1010F-FR  
12XE1110F-FR  
12XE1150F-FR